

ROOFLINE

by **timloc**

6M DRY FIX HIP KIT

INSTALLATION ADVICE

**Convenient one-pack mechanical fix
solution for roof hip installations.**



-  Helps to meet BS 5534 for slating and tiling
-  Helps to meet BS 5250 for control of condensation in buildings
-  Complies with all relevant Building Regulations
-  Independently tested and complies with BS 8612

This hip system kit is assembled from the Timloc 6m Roll Out Dry Fix Ridge System. Please note that the supplied ridge batten brackets in the pack are not required for dry hip applications. Please follow points 1 - 5 and 7 for hip tray only installations.

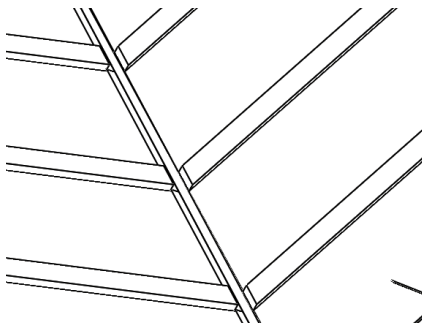

1.

Apply the roofing underlay as normal practice, maintaining a 5mm gap short of the HIP rafter at both sides to allow for ventilation.

- a.** Install the battens as normal and fix to the hip rafter directly or via noggins fixed to each side of the hip rafter (noggins would need fitting prior to underlay).

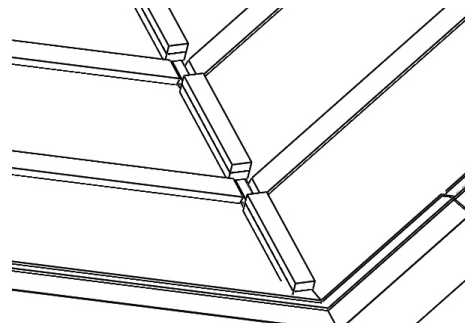

2.

Attach 50 x 50mm hip batten supports, built up from 2 x 25mm battens, directly to the hip rafter between the tile batten spaces.

- a.** Fix the hip batten supports at the eaves and ridge level and then intermittently along the line of the hip rafter.

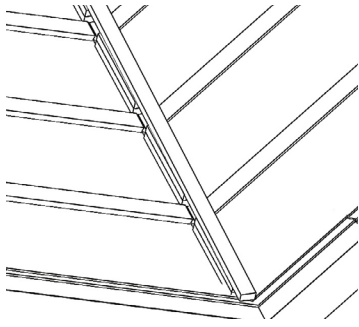

3.

Build up the hip batten by screw fixing cut-to-length 25 x 50mm battens to the 50mm deep hip batten supports, until sufficient height is achieved to allow the even fitting of the hip tiles.

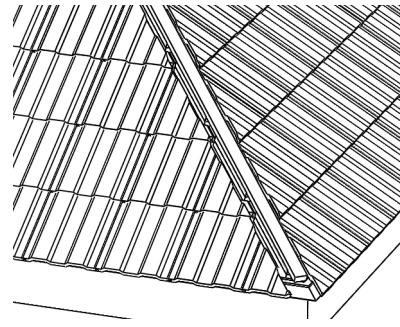

4.

Proceed to tile the roof as normal, cutting and fixing tiles neatly along the length of the hip batten.

- a. Make sure that no cut tile is more than 30mm from the hip batten and secure cut tiles with clips available from the tile manufacturer.

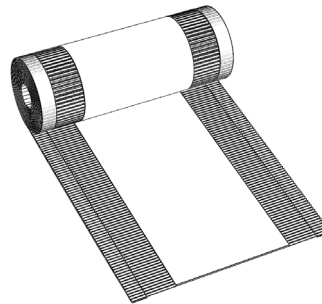
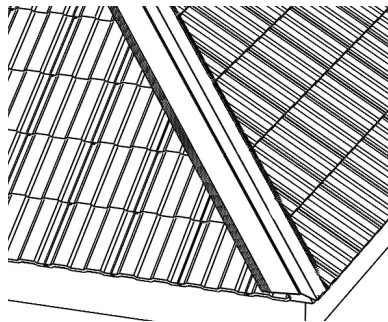

5.

Working from the eaves, lay out the 6m ridge roll centrally along the hip batten.

- a. Allow sufficient overhang to trim the ridge roll flush with the finished tiles.
- b. Tack the ridge roll in position as work proceeds using suitable roofing grade nails at 300mm intervals.
- c. At the ridge allow the roll to overhang by 100mm.
- d. If required overlap a fresh roll by a minimum of 150mm.
- e. The butyl securing tape on the underside of the corrugated ridge roll edge should be applied as work proceeds by removing the release paper and pressing the tape into the profile of the tiles. The surface will need to be free from debris and water before application.
- f. Ensure that a full seal, on both sides of the ridge roll, along the hip length is achieved.

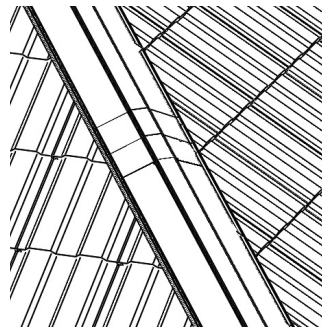
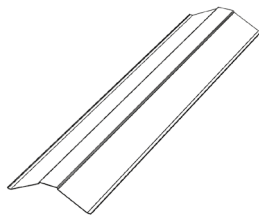

6.

Position and trim the first hip support tray at eaves level to align with the tile overhang.

- a. Secure in place along the length of the hip using appropriate roofing nails.
- b. Continue installing the hip trays by overlapping subsequent hip trays by 150mm, while working up the length of the hip and nail fix as work proceeds.

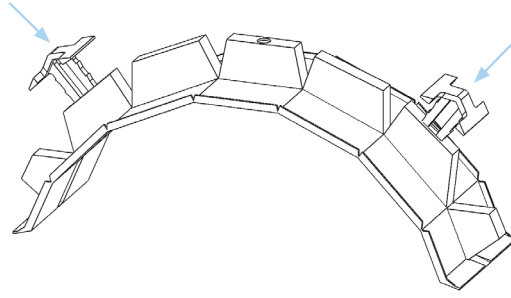

7.

Secure a block end hip tray using a sufficient fixing screw and seal method. One of the screws and seals supplied with the kit can be used in place of using a full union joint connection.

- a.** Continue up the slope securing a ridge union between each hip tile.
- b.** The plastic ridge union clips should be loosely clipped into the holes on each side of the ridge union before offering up to the hip tile.
- c.** When in position the clip can be pushed to the upper surface of the hip tile to accommodate a variation in thickness and offer a good fit.

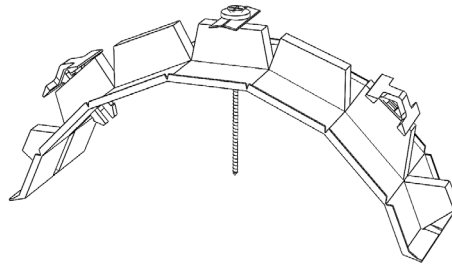
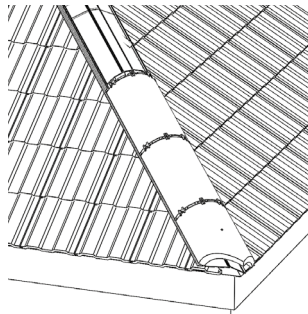

8.

Following the positioning of the adjacent hip tile, securely fix the screw, clamping plate and upper washer through the top hole in the ridge union and into the hip batten.

- a.** Repeat the process as work proceeds up to the last hip tile at the hip-ridge junction.
- b.** Close mitre both the last hip and ridge tiles and drill and fix with adequate fixing screws and seals, the ridge union screw sets supplied can be used in place of using the full ridge union set.
- c.** A small bed of mortar can be applied onto the vent roll to support the junction.
- d.** Seal the mitred joints with a roofing

Scan or click to view product datasheet

