

CAVITY SLEEVES DATASHEET

Tough, flexible ventilators for external walls

Use

- To provide ventilation through external walls to the building interior

Features & Benefits

- Unrestricted free airflow
- Lightweight and easy to handle
- Durable and totally resistant to decay

Quality

- Satisfies all NHBC requirements
- Manufactured to BS EN ISO 9001 and BS EN ISO 14001
- Complies with all relevant Building Regulations
- Meets all relevant British Standards

Material & Colour

- Injection moulded in polypropylene
- All accessories are available in black only

Products in the System

1202-1

- Suits a single 9" x 3" Timloc airbrick and provides a maximum equivalent area of 6170mm².

1202-2

- Suits a stack of two interlocked Timloc airbricks 9" x 6" and provides a maximum equivalent area of 12300mm².

1237

- Fitted to rear of 1202/1 to give maximum extension of 365mm.

1236

- Fitted to rear of 1202/2 to give maximum extension of 365mm.

1238

- Baffle to offer draught reduction inline with fitment to 1202/1 & /2.

How to Order

- Assess background ventilation required for the application and determine which sleeve is appropriate
- Remember to order the correct number of airbricks for each cavity sleeve and possible telescopic extension sleeves. Optional draft reducing baffle is available (2 x per 9" x 6")

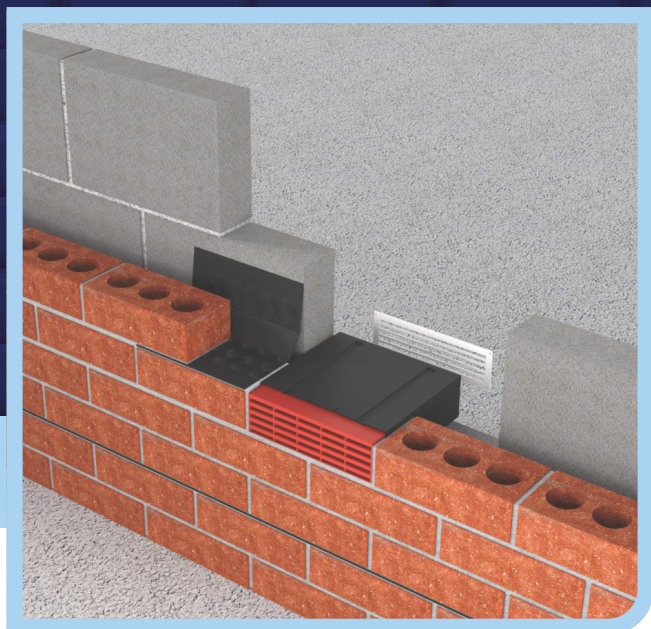

Bill of Quantity

F30 Accessories/sundry items for brick/block/stone walling

Clause

160 AIR BRICK

- To BS493, Class 1, built in as the work proceeds.
- Manufacturer: Timloc Building Products, Timloc House, Ozone Park, Howden, East Yorkshire, DN14 7SD. T: 01405 765567 W: www.timloc.co.uk
- Reference:
 - - 1202/1 Cavity Sleeve, single brick.
 - - 1202/2 Cavity Sleeve, double brick.
- Design: Rectangular
- Material: Thermoplastic
- Colour: Black

Environmental Product Declaration

A quantification of environmental information regarding the life cycle of Cavity Sleeves. GWP total is for production stages A1-A3. Verified in accordance with ISO 14025. View the full EPD at timloc.co.uk.

| Product | EPD Reference | EPD Mass (KG) | GWP A1-A3 (KG CO ₂ e) |
|---------|-------------------|---------------|----------------------------------|
| 1202/1 | EPD HUB, HUB-1836 | 0.186 | 4.65E-03 |
| 1202/2 | EPD HUB, HUB-1836 | 0.59 | 1.48E-02 |
| 1237 | EPD HUB, HUB-1836 | 0.1 | 2.50E-03 |
| 1236 | EPD HUB, HUB-1836 | 0.13 | 3.25E-03 |
| 1238 | EPD HUB, HUB-1836 | 0.08 | 2.00E-03 |

Installation Advice

- Always use in conjunction with a Timloc airbrick
- When ventilating through an external wall to a building interior, ensure the cavity sleeve and airbrick are positioned above the ground floor DPC level. The exact position will depend on what conveniently suits the interior room. Installation of the cavity sleeve and airbrick at high level in the room will help reduce the effect of draughts
- When fitted with a Timloc airbrick, the cavity sleeve suits walls up to 275mm overall thickness. If thicker walls are present, two cavity sleeves may be joined, end to end, and then trimmed to the required length and telescopic extension available
- It is strongly recommended that a section of horizontal cavity tray (Timloc Inter-loc 4 and 2 wall weeps) is positioned above the airbrick and cavity sleeve to prevent rainwater tracking across the top of the cavity sleeve
- The number of cavity sleeves and airbricks required depends on the volume of free airflow demanded by the situation
- For background ventilation into a habitable room 8000mm² of free area is required. i.e. two 9" x 3" cavity sleeves and airbricks, or a single 9" x 6" cavity sleeve and two airbricks stacked one above the other
- If ventilating a room containing a heat producing appliance the volume of free airflow will depend on the type and size of the appliance. Consult the appliance manufacturers technical information, and then provide the appropriate number and size of cavity sleeves and airbricks. Remember that each 9" x 3" airbrick provides max. 6170mm² equivalent area

Product Dimensions

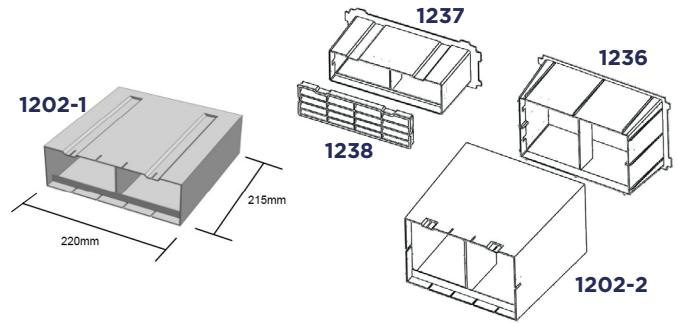

Product Codes

| Description | To Suit | Box Qty | Product Code |
|----------------------------|---------------------|---------|--------------|
| 9 x 3 cavity sleeve | 1 airbrick | 20 | 1202/1 |
| 9 x 6 cavity sleeve | 2 airbricks stacked | 1 | 1202/2 |
| 9 x 3 telescopic extension | + 90mm | 1 | 1237 |
| 9 x 6 telescopic extension | + 90mm | 1 | 1236 |
| 9 x 3 baffle | 1 airbrick | 1 | 1238 |